

ALONG THE LINES



A Touchstone Energy® Cooperative 

OCTOBER 2022

VOL.15, NO. 10

CYBERSECURITY MONTH

Tips on how to keep your personal information safe!
p.4

TROUBLE WITH TRANSFORMERS

Supply and Demand issues continue. p.6

OCTOBER IS NATIONAL CO-OP MONTH

Proudly serving our members for over 80 years.
p.7

OCTOBER CALENDAR

Oct. 7-9th: (see pg 2) Touchstone Energy Balloon Fest at Lake Shelbyville

Oct. 8th: National Motorcycle Ride Day

Oct. 12th: National Farmer's Day

Oct. 13th: Navy Birthday (1775)

Oct. 28th: National First Responder's Day & National Chocolate Day

Oct. 31st:



UPCOMING DATES

Nov. 11th: Office Closed - Veterans Day

Holidays observed:

New Year's Day, Good Friday, Memorial Day, Independence Day, Labor Day, Veterans Day, Thanksgiving Day, day following Thanksgiving and Christmas Day.





2023 SCHOLARSHIPS NOW AVAILABLE

APPLY TODAY! High School Seniors, if your primary residence is on MJM lines, you can apply for scholarships through the Association of Illinois of Electric Cooperatives and MJM!

Illinois electric cooperatives will award 15 scholarships in 2022 to financially assist deserving students in the electric cooperative family. The 15 scholarships, \$2,000 each, will be awarded through the Thomas H. Moore Illinois Electric Cooperatives (IEC) Memorial Scholarship Program.

Nine scholarships will be awarded to high school seniors who are the sons or daughters of an Illinois electric co-op member. A scholarship, the Earl W. Struck Memorial Scholarship, will be awarded to a student who is the son or daughter of an Illinois electric cooperative employee or director. Additional scholarships are reserved for students enrolling full time at a two-year Illinois community college who are the sons or daughters of Illinois electric cooperative members, employees or directors.

Only one application is needed for both the Thomas H. Moore Illinois Electric Cooperative and MJM's \$1,000 Scholarship Program.

Deadline is 12/30/22. LaVern and Nola McEntire Lineworker Scholarship Deadline is **4/30/23.**

For more info and to apply, visit:
<https://mjmec.coop/scholarships>



OCTOBER 7th - 9th

WATCH ALL THE COLORFUL BALLOONS TAKE TO THE AIR!

The Lake Shelbyville skies become a backdrop for colorful hot air balloons.

Friday evening they take off around at 5 pm (weather permitting).

Saturday and Sunday mornings the balloons take flight at dawn.

Saturday night hosts the annual Balloon Glow with food, music, and fun.



For more info and schedule, visit:

<https://www.facebook.com/balloonslakeshelbyville/>

<http://www.lakeshelbyville.com/events/balloon.htm>



#CyberAware



October is National Cyber Security Awareness Month. Educate yourself and your family on the best ways to stay safe online.



**18300 Shipman Road (PO Box 80)
Carlinville, IL 62626**

Office: 1-217-707-6156

Pay by Phone: 1-855-313-6314

Office Hours:

Monday – Friday 7:30 a.m.–4:00 p.m.

Board of Directors

- Chairman:** W. Kay Schultz.....Godfrey
- Vice Chairman:** Dennis Stewart.....Nokomis
- Secretary:** Marcie Tonsor..... Jerseyville
- Treasurer:** Robert Moore.....Medora
- Robert Lehmann.....Girard
- Tyler Heyen..... Raymond
- Dwayne Milner Piasa
- James R. NiemannLitchfield
- Charles Huebener Brighton

Staff

- Joe HeyenPresident/CEO
- Jeremy Pattillo.....Director of Finance and Accounting
- Jennifer Peterson.....Executive Administrator
- Matt Eisenmenger.....Director of Operations
- Bob Brandon.....Director of Engineering

Editor

- Eric Cooper.....Communications & Member Services Coordinator

How to report an outage:

Call 217-707-6156 or use your SmartHub app.

- When you report an outage, give your name and location number.
- Before calling, check your fuses or circuit breakers.
- Check with your neighbors. Call to report hazardous conditions.

Please do not report outages on Facebook/Social Media.

MJM Along the Lines (USPS 854-620) is published monthly for \$3.00 per year by MJM Electric Cooperative, Inc., P.O. Box 80, Carlinville, Illinois 62626. Second-class postage paid at Carlinville, IL. POSTMASTER: Send Address changes to MJM Along the Lines, P.O. Box 80, Carlinville, IL 62626.

IN THIS ISSUE

04 Cybersecurity Month
Tips on how to keep your info safe and secure.

05 Trouble with Transformers
Supply and Demand issues with Transformers

06 Energy Saving Tips
Our Power Provider Wabash Valley Power Alliance, shares some great energy and money saving tips for the changing season.

07 National Co-op Month
Celebrating Membership.

U.S. POSTAL SERVICE STATEMENT OF OWNERSHIP, MANAGEMENT, AND CIRCULATION

(Required by 39 U.S.C. 3685)
 Publication Title - M.J.M. Along the Lines.
 Publication No. - 854620.
 Filing Date – September 20, 2022
 Issue Frequency - Monthly.
 No. of Issues Published Annually - 12.
 Annual Subscription Price - \$3.00
 Complete Mailing Address of Known Office of Publication -
 18300 Shipman Road, Carlinville, IL 62626.
 Complete Mailing Address of Headquarters or General Business Office of Publisher -
 18300 Shipman Road, Carlinville, IL 62626.
 Full Names and Complete Mailing Addresses of Publisher and Editor - Publisher, M.J.M. Electric Cooperative, 18300 Shipman Road, P.O. Box 80, Carlinville, IL 62626.
 Editor – Eric Cooper, 18300 Shipman Road, P.O. Box 80, Carlinville, IL 62626.
 Owner - M.J.M. Electric Cooperative, 18300 Shipman Road, P.O. Box 80, Carlinville, IL 62626.
 Known Bondholders, Mortgages, and Other Security Holders Owning or Holding 1 percent or More of Total Amount of Bonds, Mortgages, or Other Securities –
 National Rural Utilities, 20701 Cooperative Way, Dulles, VA 20166.

Publication Name - M.J.M. Along the Lines.
 Issue Date for Circulation Data Below – September 2022.
 Extent and Nature of Circulation - Average No. of Copies Each Issue during Preceding 12 Months - Actual No. Copies of Single Issue Published Nearest to Filing Date:
 Total No. Copies - 7,900; 7,900.
 Paid and/or Requested Circulation - Sales Through Dealers and Carriers, Street Vendors, and CounterSales 0; 0. Paid or Requested Mail Subscriptions - 7,827; 7,843
 Total Paid and/or Requested Circulation - 7,827;7,843.
 Free Distribution by Mail - 0; 0.
 Free Distribution Outside the Mail - 0; 0.
 Total Free Distribution - 0; 0.
 Total Distribution – 7,827; 7,843
 Copies Not Distributed - Office Use, Leftovers, Spoiled - 73; 57;
 Returned from News Agents - 0; 0.
 Total - 7,900; 7,900.
 Percent Paid and/or Requested Circulation - 100%; 100%.

This Statement of Ownership will be printed in the October issue of this publication. I certify that all information furnished on this form is true and complete. I understand that anyone who furnishes false or misleading information on this form or who omits material or information requested on the form may be subject to criminal sanctions and/or civil sanctions.

Eric Cooper, Editor



CYBERSECURITY MONTH

Four Ways to Boost Your Cyber Hygiene

October is Cybersecurity Awareness Month

By Abby Berry (NRECA)



In today's digital world, cyberattacks are unfortunately nothing new. Cyber criminals can attack on a multitude of levels, from large-scale attacks targeting corporations to smaller phishing attacks aimed to gain an individual's personal information.

October is Cybersecurity Awareness Month, but good cyber hygiene should be practiced year-round. This year's theme is "See Yourself in Cyber" – because we all have a part to play in cybersecurity. When we hear about massive data breaches, it can feel overwhelming and lead us to think we're powerless as individuals to stop cyber criminals.

The truth is, there are several practical steps we can take to safeguard our devices and data. Here are four easy ways to boost your cyber hygiene:

1. Enable multi-factor authentication. Also known as two-step verification, multi-factor authentication adds a second step when logging into an account (to prove you're really you), which greatly increases the security of the account. This second step could include an extra PIN, answering an extra security question, a code received via email or a secure token. Regardless of the type of authentication, this additional step makes it twice as hard for cyber criminals to access your account. Not every account offers multi-factor authentication, but it's becoming increasingly popular and should be utilized when available.

2. Use strong passwords and a password manager. Remember, passwords are the "keys" to your personal home online. Your passwords should always be long, unique and complex. Create passwords using at least 12 characters, never reuse passwords for multiple accounts and use a combination of upper- and lower-case letters, numbers and special characters. If you have a lot of accounts, consider using a password manager to store them easily and securely in one place.

3. Update software. It may seem obvious, but regularly updating software is one of the easiest ways to keep your personal information secure. Most companies provide automatic updates and will send reminders so you can easily install the update. If you're not receiving automatic software updates, set a reminder to do so quarterly. Be aware that some cyber criminals will send fake updates; these typically appear as a pop-up window when visiting a website. Use good judgement

and always think before you click.

4. Recognize and report phishing attacks. Don't take the bait when cyber criminals go phishing. The signs of a phishing attack can be subtle, so take the extra time to thoroughly inspect emails. Most phishing emails include offers that are too good to be true, an urgent or alarming tone, misspellings and poorly-crafted language, ambiguous greetings, strange requests or an email address that doesn't match the company it's coming from. Most platforms like Outlook, Gmail and Mac Mail allow users to report phishing emails. If you suspect a phishing attempt, take an extra minute to report it.

Cyber criminals are here to stay, but when we all take a risk-based approach to our cyber behavior, we're creating a safer internet for all. Visit www.staysafeonline.org for additional cybersecurity tips.

Abby Berry writes on consumer and cooperative affairs for the National Rural Electric Cooperative Association, the national trade association representing more than 900 local electric cooperatives. From growing suburbs to remote farming communities, electric co-ops serve as engines of economic development for 42 million Americans across 56% of the nation's landscape.

See Yourself in Cyber.

October is Cybersecurity Awareness Month

Improve your cyber hygiene by doing these four things:

1. Enable multi-factor authentication
2. Use strong passwords and a password manager
3. Update software regularly
4. Recognize and report phishing attacks





Trouble With Transformers

Months of constricted operations at electrical transformer factories caused by the COVID-19 pandemic have strangled inventory of these essential grid devices. Add to that spiking demand from new housing developments, scarcity of raw and finished materials, bottlenecks at shipping ports and a shortage of freight drivers, and it's a recipe for a long-term supply crunch. Here are some of the key drivers of the current national transformer shortage.

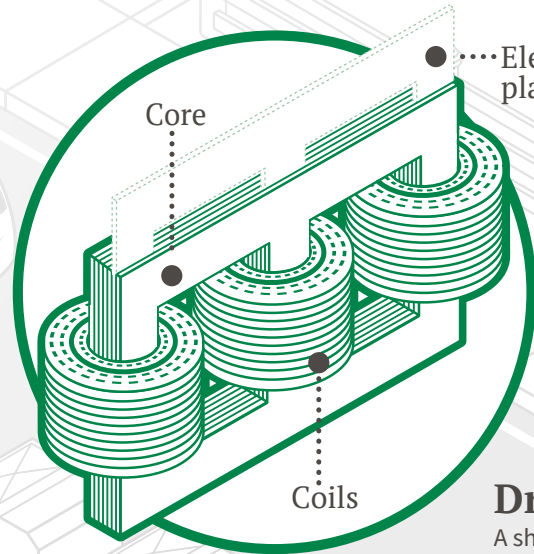

••••• Electrical steel plates

Electrical Steel

A global shortage of electrical steel, a key component in transformers, is slowing production.

Labor Shortages

A tight labor market is causing difficulties in hiring and retaining factory worker and technicians.

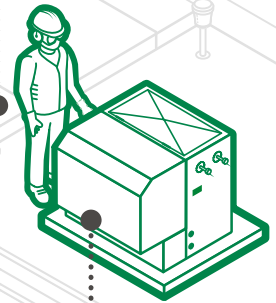

Driver Shortages

A shortage of truck drivers and warehouse workers is impeding deliveries of finished products.

High Demand

Developments in growing areas of the country and summer storm prep are spiking the need for new transformers.

Shipping Bottlenecks

Imports of components made overseas are being delayed by labor shortages at U.S. shipping ports.

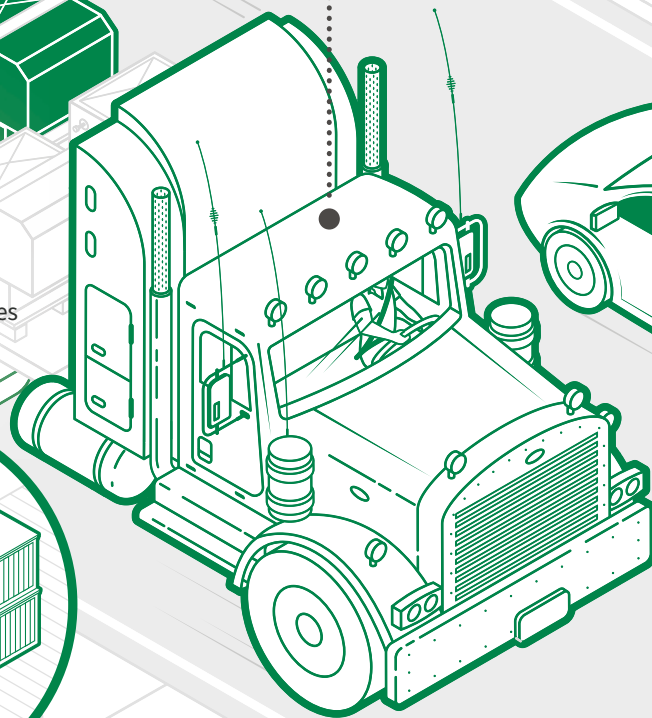

Electric Vehicles

Much of the world's tight supply of electrical steel is being absorbed by the booming EV market.





Wabash Valley Power news



Get energy treats (and avoid getting tricked!) this October

This October, you should be treated by ghoulish figures visiting on Halloween — not tricked by unexpectedly high energy costs.

Every fall, people enjoy the milder temperatures while preparing for the coming Midwestern winter. Make sure you're treating yourself to energy savings by making the right upgrades.

Even small home improvements can lead to long-term energy savings. Contact your local electric co-op's energy advisor for tips on how you can improve your home's energy use, or visit [PowerMoves.com](https://www.powermoves.com).



BUY A MINI-SPLIT — NOT A SPACE HEATER

Electric resistance space heaters have been a go-to solution for cold, uncomfortable rooms. That easy solution to a cold room comes with a high price once the monthly electricity bill comes due. Instead, consider a mini-split heat pump, which can add a little extra heat much more affordably than an electric resistance space heater. Mini-split heat pumps come in a range of heating capacities, so you can find one to heat rooms big and small. Don't forget that there are also Power Moves rebates to make mini-splits even more affordable.

BUY MORE AIR SEALING — NOT A WHOLE HOME HUMIDIFIER

Living in a home with dry, staticky winter air is not fun. Most people think they need a humidifier. Yet excessively dry winter air is a symptom of a poorly air-sealed home. A better idea is to have an energy audit and blower door test conducted. This can find holes, gaps and cracks in the home that let hot air escape. Proper air sealing reduces how much conditioned air escapes, keeping your energy bills low and humidity levels comfortable.

BUY CEILING FANS WITH LONGER BLADES — NOT STUBBY ONES

Energy Star recommends ceiling fans installed in rooms 144 to 400 square feet should have a total blade span (from one fan blade edge to the edge of the opposite fan blade) between 44 and 54 inches. Consider a smaller blade span for smaller rooms and, conversely, a longer blade span for larger rooms. Ceiling fans sized too small will waste energy by spinning without the person in the room feeling enough air movement.

BUY A COLD CLIMATE AIR SOURCE HEAT PUMP — NOT AN ELECTRIC FURNACE

While you may be aware of air source heat pumps, cold climate heat pumps have improved compressors that enable them to be at least 75% more efficient than an electric furnace when it is 5 degrees outside. Add in Power Moves® rebates for installing cold climate heat pumps and you can experience big-time money savings in long-term energy costs!



Focused on YOU.

Electric cooperatives were created to serve their members. Because we're a co-op, we're able to adapt to our community's unique needs. That's the power of co-op membership.

OCTOBER IS NATIONAL CO-OP MONTH

CELEBRATING MEMBERSHIP

Fall is a busy time, and October is a particularly eventful month with school, community, and sports activities in full swing. It's also when all cooperatives celebrate National Co-op Month.

When I say MJM celebrates Co-op Month, it really means we are celebrating you! After all, our co-op wouldn't exist without you, our members.

Our core business purpose is to serve as your electricity provider, but the larger mission of the co-op is to help make our corner of the world a better place. "Concern for community" is one of seven guiding principles that all co-ops share.

Similar to how our wires run through our service territory, our concern for community flows through all of our decisions--because being a co-op means being a responsible partner and good neighbor.

MJM works to help our community thrive through initiatives led by our employees and local board that's comprised of neighbors who live right here in our community. Because we're local, we understand our community's unique needs and strive to help meet them. We're proud to support local youth through our Youth Tour and scholarship programs. With your help, we offer Operation Round Up to provide assistance to our community's charity programs.

The word "cooperative" is close to "cooperation," meaning people working together towards a common goal--

mutually benefitting one another and the larger community. That's the essence of the cooperative spirit. Our employees and member-elected board members are invested in the community in which live and serve.

Above all, as a co-op we put our members' priorities first. As your trusted energy partner, we know that saving energy and money is important to you. We want to empower you to manage energy use at home. If you haven't already, I encourage you take a moment and download our app, SmartHub. Through the app, you can conveniently monitor and manage your energy use. And we're of course here to help, so give us a call if you have questions about your energy bills.

MJM is continuously examining ways to operate more efficiently while continuing to provide the highest level of friendly, reliable service you expect and deserve. After all, we're your local co-op. We were built by the members we serve.

THANK YOU MJM MEMBERS!



By Anne Prince (NRECA)

Anne Prince writes on consumer and cooperative affairs for the National Rural Electric Cooperative Association, the national trade association representing more than 900 local electric cooperatives. From growing suburbs to remote farming communities, electric co-ops serve as engines of economic development for 42 million Americans across 56% of the nation's landscape





MEMBER TRADING POST

FOR SALE: DMI TigerTwo ripper, like new condition, 5 points, Front blades 18.5 in, Back blades 14.5 in Approx. 13 ft width. New rippers. Tires in great condition Can provide photos 217-556-7511

FOR SALE: LP Gas Unvented fireplace insert. Empire brand 24" , 36,000 BTU burner with Sassafras log set. With remote. \$140 obo. Call/ text Dan @ 217-473-3734

To list your free ad, email ericc@mjmec.coop, call 217-707-6156, or mail the ad to MJM Electric Cooperative, P.O. Box 80, Carlinville, IL 62626.

Each ad will run for one month. Some restriction may apply.

Energy Efficiency Tip of the Month

If you can see daylight around a window frame or if you can rattle a window (movement means possible leaks), the window likely needs to be sealed.

Most window leaks can be sealed with caulk or weatherstripping, which come in a variety of compounds and materials.

Visit www.energy.gov/energysaver to learn how and where to seal air leaks.

Source: energy.gov

